

Note

N^1, N^7 -expeditious dialkylation of cyclen (1,4,7,10-tetraazacyclododecane). An astonishing reactivity of cyclen tricarbonyl molybdenum and chromium complexes

V. Patinec, J.J. Yaouanc, H. Handel, J.C. Clément and H. des Abbayes*

Unité de recherche associée au CNRS, No. 322, Faculté des Sciences et Techniques, 6 Avenue le Gorgeu, BP 809, 29285 Brest Cedex (France)

(Received January 5, 1994)

Abstract

After reaction with alkyl iodides and subsequent oxidative removal of the $M(CO)_3$ triprotection, molybdenum and chromium *fac*- $LM(CO)_3$ complexes of cyclen (L) unexpectedly lead to N^1, N^7 -dialkylated cyclen derivatives.

Key words: Molybdenum complexes; Chromium complexes; Carbonyl complexes; Tetraazamacrocycle complexes

The problem of the selective alkylation of tetraazamacrocycles (to give them specific properties [1]) is still a challenge for which several solutions have been given very recently. Among them is the temporary triprotection with Group 6 metal carbonyls [2, 3]. This methodology raises several questions: will the reaction with $M(CO)_6$ give a tricomplexed ligand with an uncomplexed nitrogen atom whatever the ring size? Furthermore, if this condition is satisfied, will we observe a monoalkylation on the uncomplexed nitrogen atom? The first issue has been studied and the ring size conditions giving rise to a tricomplexation will be addressed elsewhere.

We report here some new results of this methodology, on the example of cyclen, which are an attempt at answering the second question, and also are a new methodology for the regioselective N, N'' -dialkylation of tetraazamacrocycles.

The chemistry of cyclen (1,4,7,10-tetraazacyclododecane) derivatives is strongly limited by the diffi-

culties encountered during their synthesis; for instance N^1, N^7 -dimethyl-1,4,7,10-tetraazacyclododecane has been prepared through a multistep, time consuming synthesis, involving the classical *n*-tosyl protection/deprotection sequence [4].

As a major improvement of the synthesis of N^1, N^7 -dialkylated cyclen derivatives we now report a direct method starting from the macrocycle itself via its chromium and molybdenum *fac*- $LM(CO)_3$ complexes.

In a previous communication [2], we described the mono *N*-alkylation of tetraazamacrocyclic compounds through the reaction of their *fac*- $LM(CO)_3$ chromium complexes with alkyl bromides (Scheme 1, path (a)).

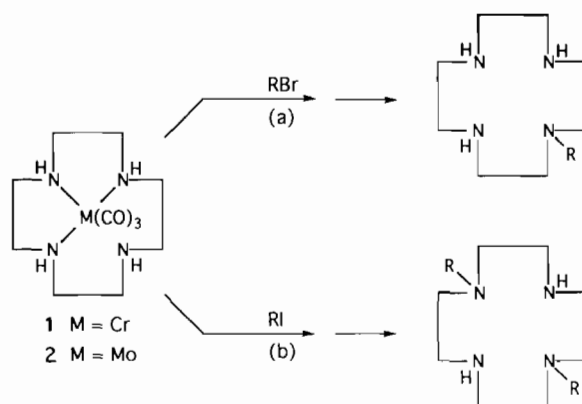

Scheme 1.

This very selective procedure of mono *N*-alkylation, relying on the temporary triprotection [2, 3, 5] of tetraamines by the $M(CO)_3$ moiety, unexpectedly failed when applied to the reaction of these *fac*- $LM(CO)_3$ complexes with alkyl iodides (Scheme 1, path (b)): after oxidative removal of the protection, as sole detected product, were obtained the N^1, N^7 -disubstituted derivatives as established by comparison with the literature data of N^1, N^7 -dimethyl cyclen [4]. Therefore, the simple replacement of an alkyl bromide by an alkyl iodide in this reaction dramatically modifies the results. Such a N^1, N^7 -difunctionalization of cyclen has already been reported by others [6] as the result of its tricyclic orthoamide hydrolysis (eqn. (1)), however the reasons for this very high regioselectivity have not been explained.

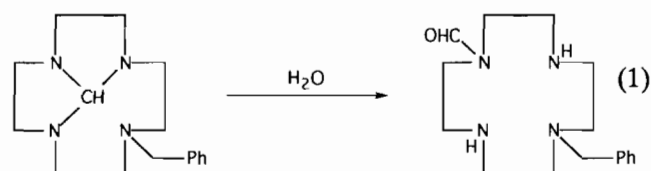

*Author to whom correspondence should be addressed.

As shown in Table 1, a series of alkyl iodides has been submitted to this new procedure, allowing the straightforward preparation of four N¹,N⁷-dialkylated cyclen derivatives.

The following procedure is typical.

Complex **2** [2] (1.0 mmol) is dissolved in dry and degassed *N,N*-dimethylformamide (20 ml); dry Na₂CO₃ (5.0 mmol) and the appropriate alkyl iodide (see Table 1 for the stoichiometry) are added and allowed to react with stirring under a nitrogen atmosphere for 48 h at room temperature. The solution is then filtered under nitrogen, the solvent removed *in vacuo* and the residue taken up in 10% aqueous degassed HCl. The resulting mixture is oxidized in air until no more CO evolves. This acidic solution is washed with dichloromethane (2 × 25 ml), then made alkaline (pH 14) with NaOH pellets with cooling; extraction with dichloromethane (2 × 50 ml), drying and subsequent removal of the solvent finally give the N¹,N⁷-dialkylated cyclen derivatives.

All the N¹,N⁷-dialkylated cyclen derivatives gave satisfactory ¹H and ¹³C NMR and mass spectral data (¹³C data are reported in Table 2).

TABLE 1. Stoichiometry and yield for each alkyl iodide

| R(I) | x (stoichiometry) | N ¹ ,N ⁷ -dialkylated cyclen yield (%) |
|--------|----------------------|--|
| Me | 2 | 67 |
| Et | 2 | 70 |
| n-Pr | 3 | 77 |
| Benzyl | 3 | 55 |

TABLE 2. ¹³C NMR data (CDCl₃; 75.47 MHz) for N¹,N⁷-dialkylated cyclen

| R | δ (ppm) |
|--------|---|
| Me | 54.0; 44.6 (CH ₂ α-N); 43.8 (CH ₃) |
| Et | 50.9; 48.4; 45.3 (CH ₂ α-N); 12.1 (CH ₃) |
| n-Pr | 57.0; 51.6; 45.9 (CH ₂ α-N); 20.2 (CH ₂ β-N); 11.4 (CH ₃) |
| Benzyl | 138.8; 128.7; 128.0; 126.9 (C ₆ H ₅); 59.7; 51.3; 45.0 (CH ₂ α-N) |

This new highly selective procedure, in which the total synthesis of the macrocycle itself is not required, is the most efficient method of cyclen dialkylation.

As the reaction of alkyl bromides with *fac*-LM(CO)₃ has been shown to proceed via a SN₂ mechanism at the free nitrogen atom [7], it is very likely that the second alkylation which occurs with alkyl iodides, is under the control of the metal itself; the participation of the metal is currently under investigation. A further paper to be published elsewhere will be devoted to the 'bromide'/iodide' sequence which allows the N¹,N⁷-dissymmetrical dialkylation of cyclen.

Acknowledgements

The CNRS is gratefully acknowledged for financial support, SIMAFEX (17230 Marans, France) for generous gifts of cyclen trisulfate and alkyl iodides, and Dr R. Pichon for recording NMR spectra.

References

- 1 A. Bencini, A. Bianchi, P. Dapporto, V. Fusi, E. Garcia-España, M. Micheloni, P. Paoletti, P. Paoli, A. Rodriguez and B. Valtancoli, *Inorg. Chem.*, **32** (1993) 2753, and refs. therein.
- 2 J.J. Yaouanc, N. Le Bris, G. Le Gall, J.C. Clément, H. Handel and H. des Abbayes, *J. Chem. Soc., Chem. Commun.*, (1991) 206.
- 3 J.J. Yaouanc, N. Le Bris, J.C. Clément, H. Handel and H. des Abbayes, *J. Chem. Soc., Chem. Commun.*, (1993) 696.
- 4 M. Ciampolini, M. Micheloni, N. Nardi, P. Paoletti, P. Dapporto and F. Zanobini, *J. Chem. Soc., Dalton Trans.*, (1984) 1357.
- 5 N. Le Bris, J.J. Yaouanc, J.C. Clément, H. Handel and H. des Abbayes, *Tetrahedron Lett.*, **34** (1993) 5429.
- 6 P.L. Anelli, M. Murru, F. Uggeri and M. Virtuani, *J. Chem. Soc., Chem. Commun.*, (1991) 1317.
- 7 V. Patinec, J.J. Yaouanc, H. Handel, J.C. Clément and H. des Abbayes, to be published.